

### APPLICATION

MGM Model 230 Back Pressure Check Valves are designed to allow flow in one direction only. The check mechanism is held in the closed position by a spring, which stops flow in the reverse direction. When pressure from flow in the permitted direction overcomes the force of the spring, the check mechanism opens. When this flow stops or reverses, the check closes. The metal-to-metal seating allows slight leakage after closure. The valves are recommended for use in all inflowing lines.

Model 230 Back Pressure Check Valves are designed for installation in lines that flow into pressure tanks where flanged connections are required. These valves should be used in inflowing lines when outward flow is never required.

Model 230 Back Pressure Check Valves can be mounted in any orientation. Each valve will have the proper flow direction indicated by an arrow stenciled into the body. As with all MGM Back Pressure Check Valves, do not reduce outlet pipe size. Back Pressure Check Valves should be installed as close as possible to the container, with the poppet stem pointed inwardly toward the container.

### FEATURES

- Designed to fit between 150 or 300 pound American Standard steel pipe flanges. Ring groove flanges can be furnished if required.
- Generous flow channels provide minimal pressure drops.
- Heavy duty A350-LF2 steel construction will withstand temperatures from -50° F (-45° C) to +300° F (+148° C) and internal pressures up to 2000 psig (138 barg).
- Complete stainless steel construction available for greater range of operating temperatures.

### PRODUCT CERTIFICATIONS



**Underwriters Laboratories, Inc.**  
Listed for propane, butane, and anhydrous ammonia



**Canadian Registration Number**  
OC13500.5C



**CE Mark** Certified to Pressure  
Equipment Directive 2014/68/EU

### STANDARD MATERIALS

The table below lists standard material configuration for carbon steel and 316 stainless steel valves.\*

	Carbon Steel	316 Stainless
<i>Body</i>	<i>Low-temp Carbon</i>	<i>316-SS</i>
<i>Guide</i>	<i>Low-temp Carbon</i>	<i>316-SS</i>
<i>Spring</i>	--- 316- or 302-SS ---	
<i>Poppet (incl. nut and cotter pin)</i>	--- 316-SS ---	

\*Alternative materials available at additional cost

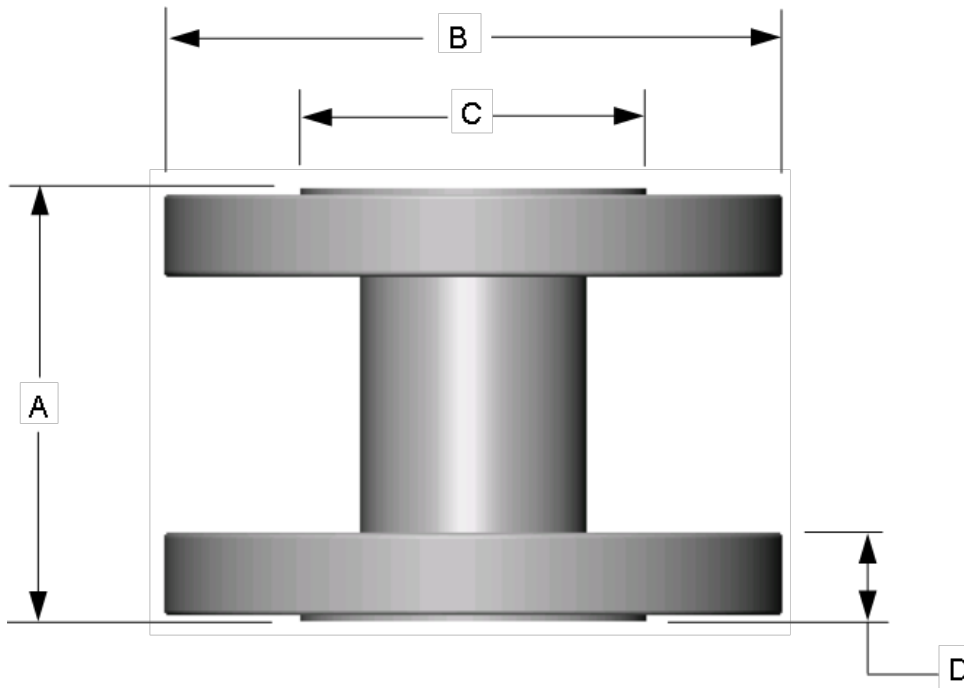

ORDERING INFORMATION					
Model Number	Pipe Size	Dimensions (inches) (300 # shown)			
		A	B	C	D
230:H	1.5"	3.75	6.125	2.88	0.813
230:I	2.0"	4.50	6.50	3.63	0.88
230:J	2.5"	5.00	7.50	4.13	1.00
230:K	3.0"	5.25	8.25	5.00	1.13
230:L	3.5"	5.63	9.00	5.50	1.19
230:M	4.0"	6.00	10.00	6.19	1.25
230:N	5.0"	7.00	11.00	7.31	1.38
230:P	6.0"	8.63	12.50	8.50	1.44
230:Q	8.0"	10.00	15.00	10.63	1.63
230:R	10.0"	13.13	17.50	12.75	1.88

*\*Contact MGM for flow rates of other fluids*